

Klenzor™ 16

Klenzor™ 18 MPH

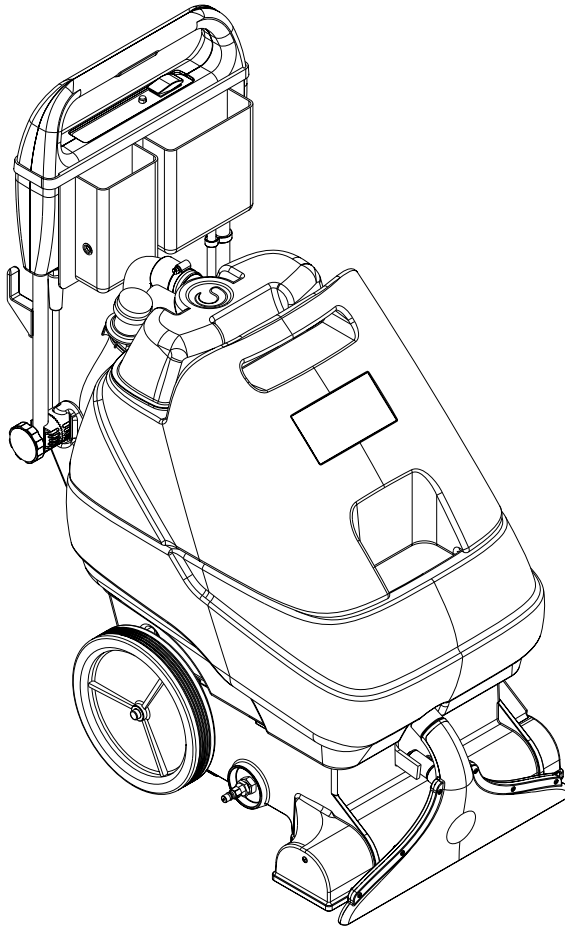

PARTS LIST

Kent MODELS 56265004(16), 56265005(18)

KENT

Simple. Clean.

12/04 revised 10/06 FORM NO. 56042453

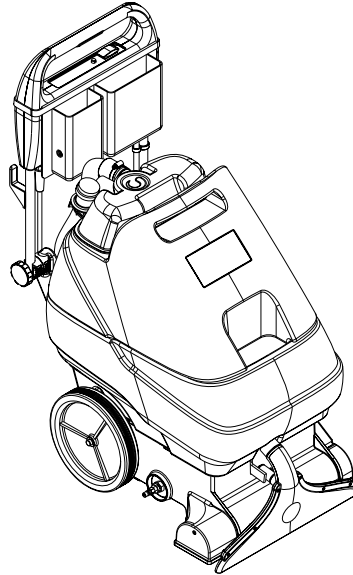

DESCRIPTION	PAGE
Base System	2-3
Brush System	4-5
Decal System	6-7
Handle System 16	8-9
Handle System 18	10-11
Recovery System	12-13
Solution Pump System	14-15
Solution Tank Assembly	16-17
Wiring Diagram	18-19
Hard Floor Tool Kit	20-21
Accessories	22

WHEN ORDERING PARTS

- * Use the 8 digit numbers from the "Ref. No." columns in this parts list.
- * Specify the model and serial number of the machine.
- * Use the space below to record the model and serial number for future reference.

Model _____ Serial No. _____

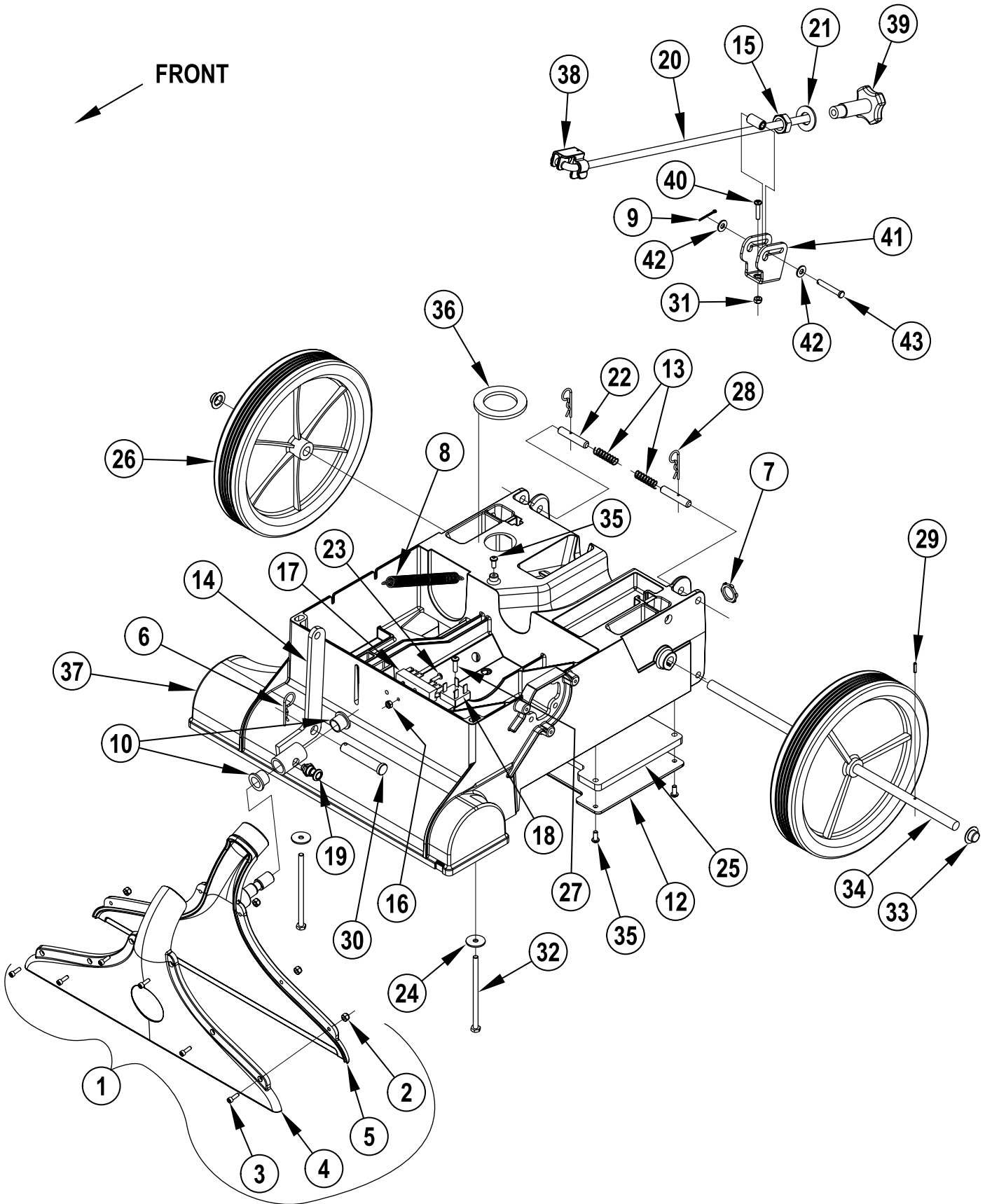

Item	Ref. No.	Qty	Description
1	56265067	1	Shoe Assembly, 16 (Klenzor 16) (items 2-5)
	56265080	1	Shoe Assembly, 18 (Klenzor 18) (items 2-5)
2	56002865	6	Nut, Hex Nyl Loc-Thin 8-32
3	56002101	6	Scr, Soc Hd 8-32 x 0.50
4	56265068	1	Shoe Front, 16
	56265081	1	Shoe Front, 18
5	56265069	1	Shoe Back, 16, Assy
	56265082	1	Shoe Rear, 18, Assy
6	56002959	1	Pin, Cotter Hair
7	56009095	1	Nut, Conduit Lock 1/2-14
8	56398606	1	Spring, Ext .50 x 6.25
9	56002166	1	Pin, Cotter 3/32 x 3/4
10	56171095	2	Bearing, Flange
11			Intentionally Omitted
12	56265172	1	Panel, Exhaust
13	56228142	2	Spring, Compression
14	56265116	1	Linkage Weldment, 16 (16)
	56265144	1	Linkage Weldment, 18 (18)
15	56002844	1	Nut, Hex Nyl Loc-Thin 5/8-11
16	56002865	1	Nut, Hex Nyl Loc-Thin 8-32
17	56260071	1	Terminal Block
18	56265103	1	Rectifier, 35 Amp
19	56365548	1	Lock Pin Assy
20	56265111	1	Adjustment Rod Weldment
21	56002022	1	Wsh, Flt SAE 5/8
22	56265073	2	Pin, Pivot
23	56002146	1	Scr, Pan Phil 8-32 x .62
24	56009060	2	Wsh, Flt SS .260 x 1.000 x .074
25	56265071	1	Gasket, Exhaust
26	56249505	2	Wheel
27	56003091	1	Scr, Pan Phil Plastite 10-14 x .75
28	56003120	2	Pin, Cotter Hair .0915 x .375
29	56003133	1	Pin, Spr .12 x .56
30	56003207	1	Clevis Pin .50 x 2.75
31	56002832	1	Nut, Hex Nyl Loc-Thin 10-24
32	56003691	2	Scr Hex Loc SS 1/4-20 x 4.50
33	56009097	2	Nut, Push Cap 1/2
34	56265057	1	Axle
35	56009191	5	Scr, Pan Phil Plastite 10-14 x .50
36	56200573	1	Gasket, Ring 1.75 x 2.75 x .19
37	56265020	1	Base, Extractor, 16 (16)
	56265120	1	Base, Extractor, 18 (18)
38	56265031	1	Clip, Rod
39	56265036	1	Knob, Brush Adjustment
40	56002674	1	Scr, Pan Phil 10-24 x 1.00
41	56265119	1	Latch, Adjustment
42	56002098	2	Wsh, Flt SAE 1/4
43	56003193	1	Clevis Pin .25 x 1.625

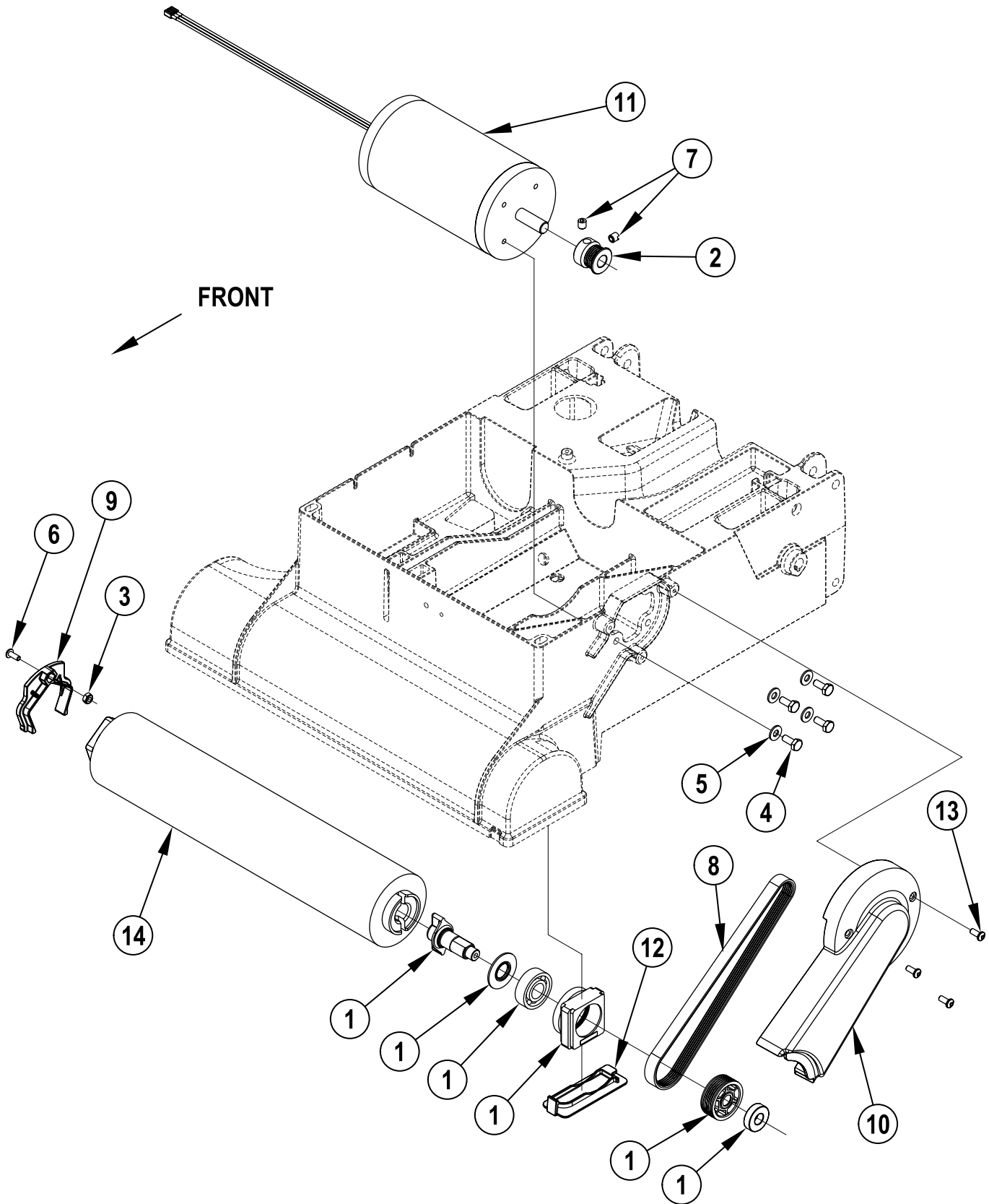

04-12

BRUSH SYSTEM

05-3

Klenzor™ 16, 18 MPH**5**

Item	Ref. No.	Qty	Description
1	56265204	1	Bearing/Spindle Kit
		1	Spindle, Drive
		1	Washer, Bearing
		1	Bearing, Block
		1	Sheave Poly-V 6J17
		1	Bearing, Ball
		1	Bearing, Ball
2	56262558	1	Sheave, Poly-V
3	56002849	1	Nut, Hex Nyl Loc-Thin SS 10-24
4	56001854	4	Scr, Hex Hd 1/4-20 x .50
5	56002098	4	Wsh, Flt SAE 1/4
6	56002900	1	Scr, Pan Phil SS 10-24 x .50
7	56009131	2	Scr, Soc Set Loc 5/16-18 x .31
8	56265024	1	Belt, Poly V
9	56265043	1	Clip, Brush Retainer
10	56265047	1	Belt Guard
11	56265075	1	Motor, 115 VDC, 1/3 HP
12	56265091	1	Cover, Pulley
13	56009191	3	Scr, Pan Phil Plastite 10-14 x .50
14	56265044	1	Brush Assembly 16
	56265046	1	Brush, 16
	56265099	1	Brush Assembly 18
	56265065	1	Brush, 18

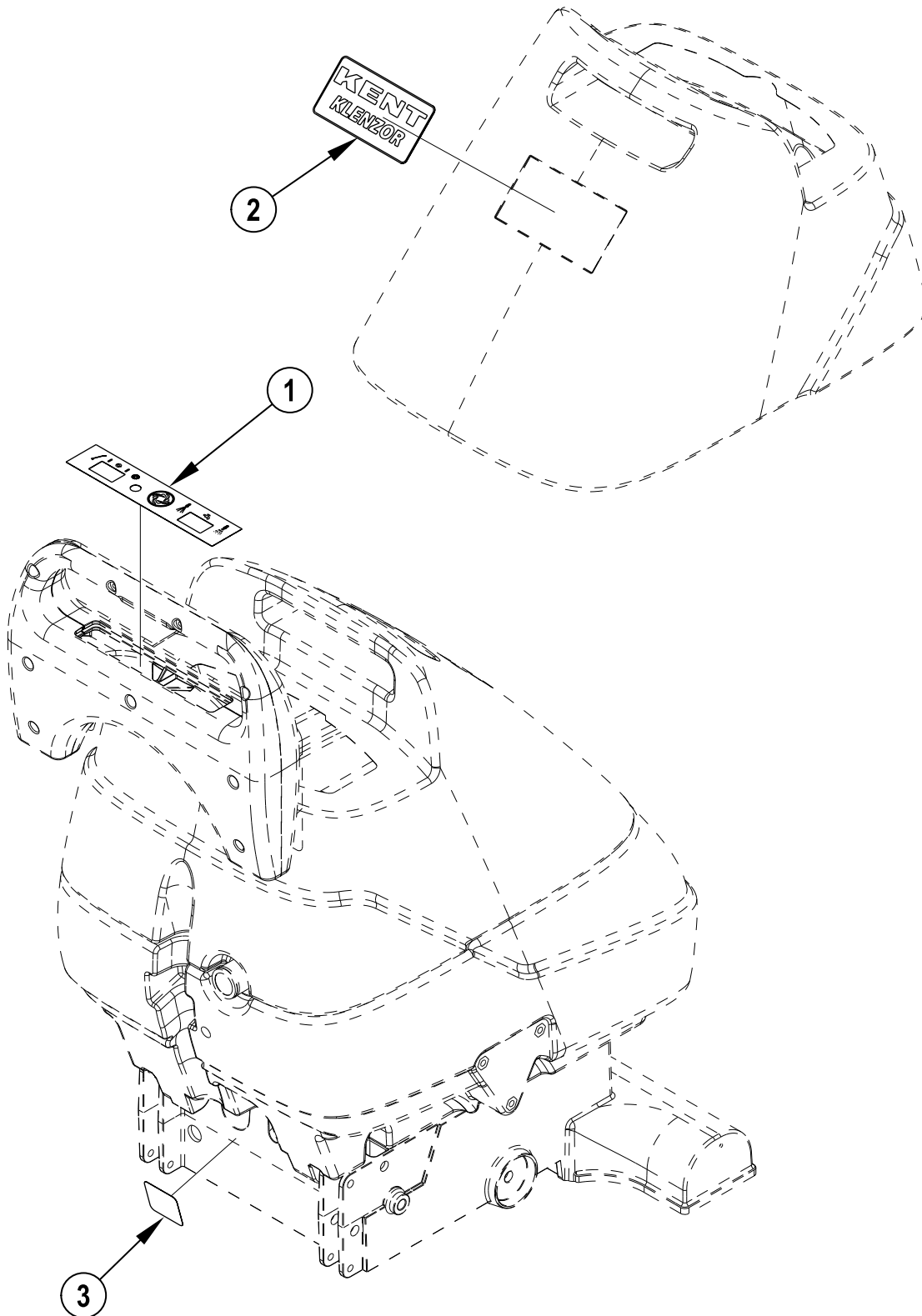

04-12

DECAL SYSTEM

Klenzor™ 16, 18 MPH

7

Item	Ref. No.	Qty	Description
1	56016717	1	Decal, Panel (18)
	56016716	1	Decal, Panel (16)
2	56016723	1	Decal, Kent Klenzor
3	56016718	1	Decal, Brush Pressure

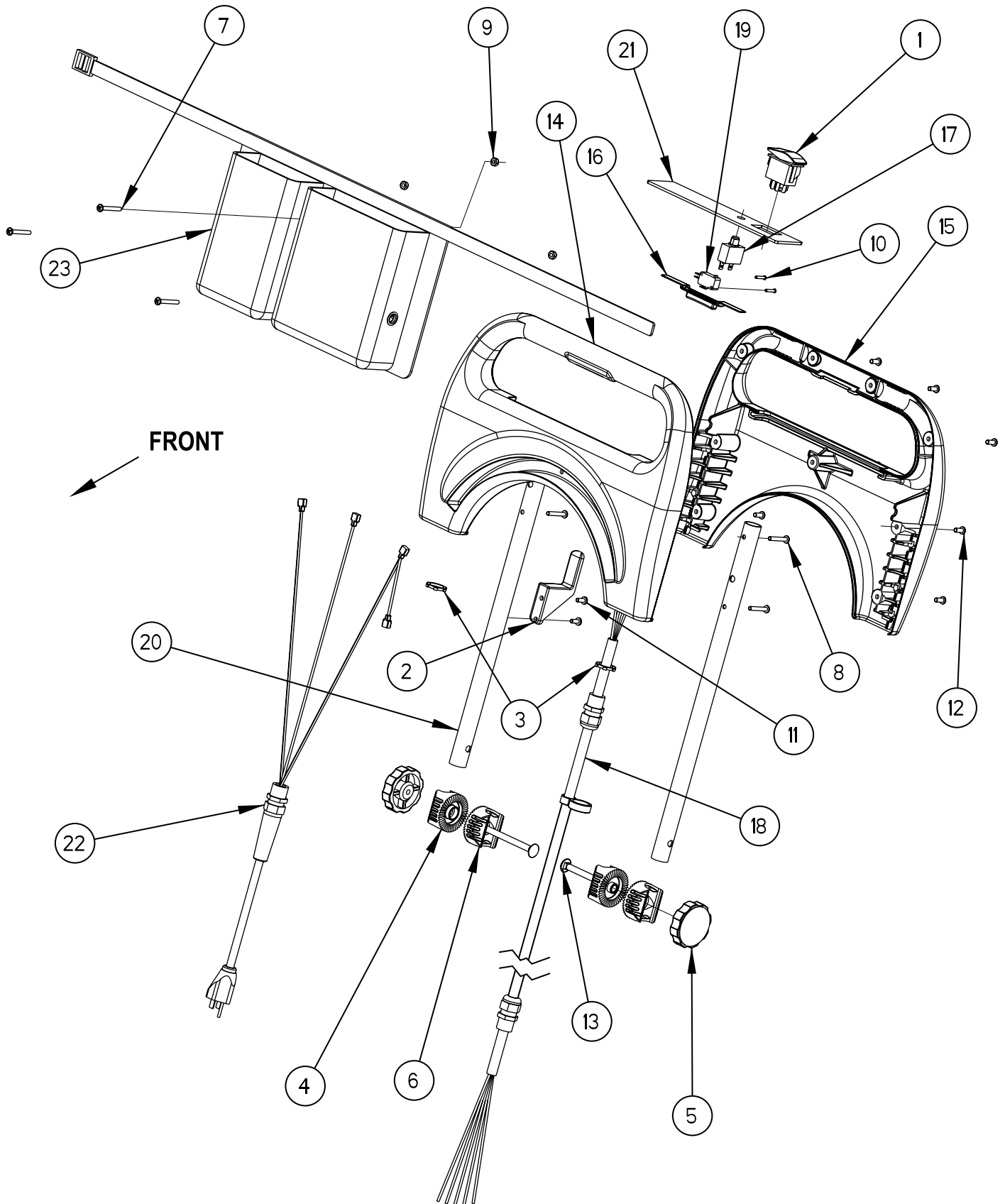

Item	Ref. No.	Qty	Description
1	56265097	1	Switch, Rocker
2	56262518	1	Hook, Cord
3	56009095	2	Nut, Conduit Lock 1/2-14
4	56264123	2	Ratchet
5	56302167	2	Knob
6	56264118	2	Ratchet
7	56002231	3	Scr, Pan Phil 10-24 x 1.50
8	56002824	4	Scr, Pan Phil 10-24 x 1.25
9	56002832	3	Nut, Hex Nyl Loc-Thin 10-24
10	56003092	2	Scr, Pan Phil Plastite 4-20 x .62
11	56009029	2	Scr, Pan Phil Thd Form 10-24 x .50
12	56009191	9	Scr, Pan Phil Plastite 10-14 x .50
13	56009227	2	Scr, Carriage 5/16-18 x 3.50
14	56265028	1	Cover, Handle, Front
15	56265029	1	Cover, Handle, Rear
16	56265053	1	Button, Spray
17	56265056	1	Circuit Breaker W/Boot
18	56265085	1	Main Cable Assy
19	56265098	1	Switch, SPDT Snapaction
20	56265143	2	Tube, Handle
21	56265159	1	Panel, Control
22	56265162	1	Cord, Power 14/3, SJT
23	56265198	1	Bag, Utility

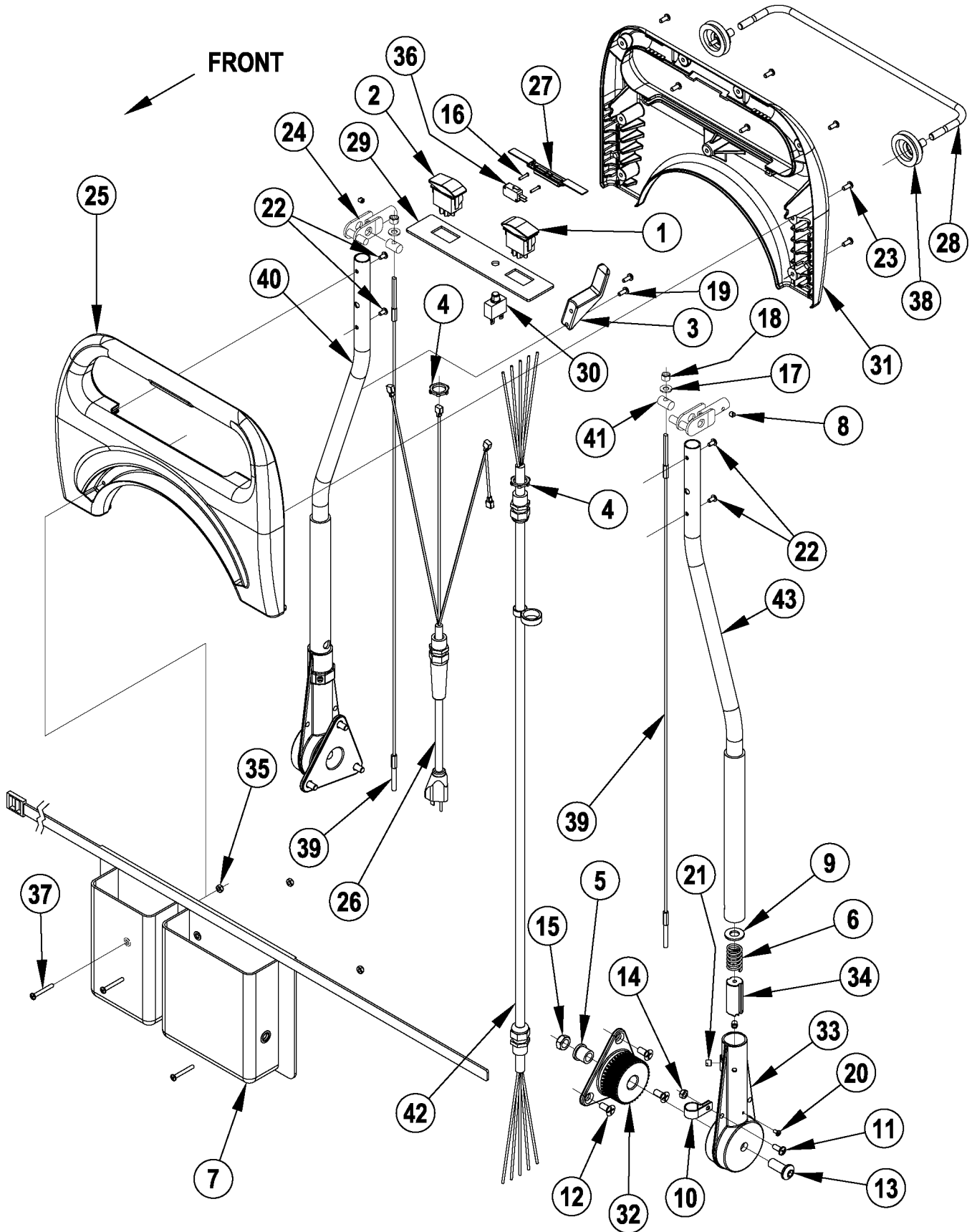

Item	Ref. No.	Qty	Description
1	56265097	1	Switch, Rocker (vacuum)
2	56265107	1	Switch, Rocker (solution)
3	56262518	1	Hook, Cord
4	56009095	2	Nut, Conduit Lock 1/2-14
5	56111503	2	Bearing, Flange
6	56056519	2	Compression Spring
7	56265198	1	Bag, Utility
8	56001841	2	Scr, Soc Set Loc 1/4-20 x .25
9	56009003	2	Wsh, Flt .516 x .938 x .075
10	56486112	1	Clamp, P
11	56002066	2	Scr, Pan Phil 1/4-20 x .62
12	56002395	6	Scr, Flt Phil 5/16-18 x .75
13	56009341	2	Scr, Button Soc 1/2-13 x 1.50
14	56002840	1	Nut, Hex Nyl Loc-Thin 1/4-20
15	56002843	2	Nut, Hex Nyl Loc-Thin 1/2-13
16	56003092	2	Scr, Pan Phil Plastite 4-20 x .62
17	56002098	2	Wsh, FLT SAE 1/4
18	56003284	2	Nut, Hex Nyl Loc 1/4-28
19	56009029	2	Scr, Pan Phil Thd Form 10-24 x .50
20	56009066	2	Scr, Pan Phil 8-32 x .31
21	56009131	4	Scr, Soc Set Loc 5/16-18 x .31
22	56009139	4	Scr, Pan Phil Loc 10-24 x .38
23	56009191	9	Scr, Pan Phil Plastite 10-14 x .50
24	56265241	2	Handle Adjustment Pivot NOTE 1
25	56265028	1	Cover, Handle, Front
26	56265162	1	Cord, Power 14/3, SJT
27	56265053	1	Button, Spray
28	56265054	1	Bail, Handle Release
29	56265055	1	Panel, Control
30	56265056	1	Circuit Breaker W/Boot (5 amps)
31	56265062	1	Cover, Flip Handle, Back
32	56265074	2	Gear, Handle
33	56265083	2	Handle Socket
34	56265084	2	Lock, Handle
35	56002832	3	Nut, Hex Nyl Loc-Thin 10-24
36	56265098	1	Switch, SPDT Snapaction
37	56002231	3	Scr, Pan Phil 10-24 x 1.50
38	56265128	2	Bellows, Handle
39	56265147	2	Wire Rope Assy
40	56265157	1	Tube, Handle
41	56265242	2	Pin NOTE 2
42	56265192	1	Main Cable Assy
43	56265197	1	Tube, Handle

NOTE 1: Pivot Weldment 56265023 is obsolete and has been replaced by Handle Adjustment Pivot 56265241 in production. Order Kit 56265191 when replacing 56265023.

NOTE 2: Pin 56265164 is obsolete and has been replaced by Pin 56265242 in production. Order Kit 56265191 when replacing 56265164

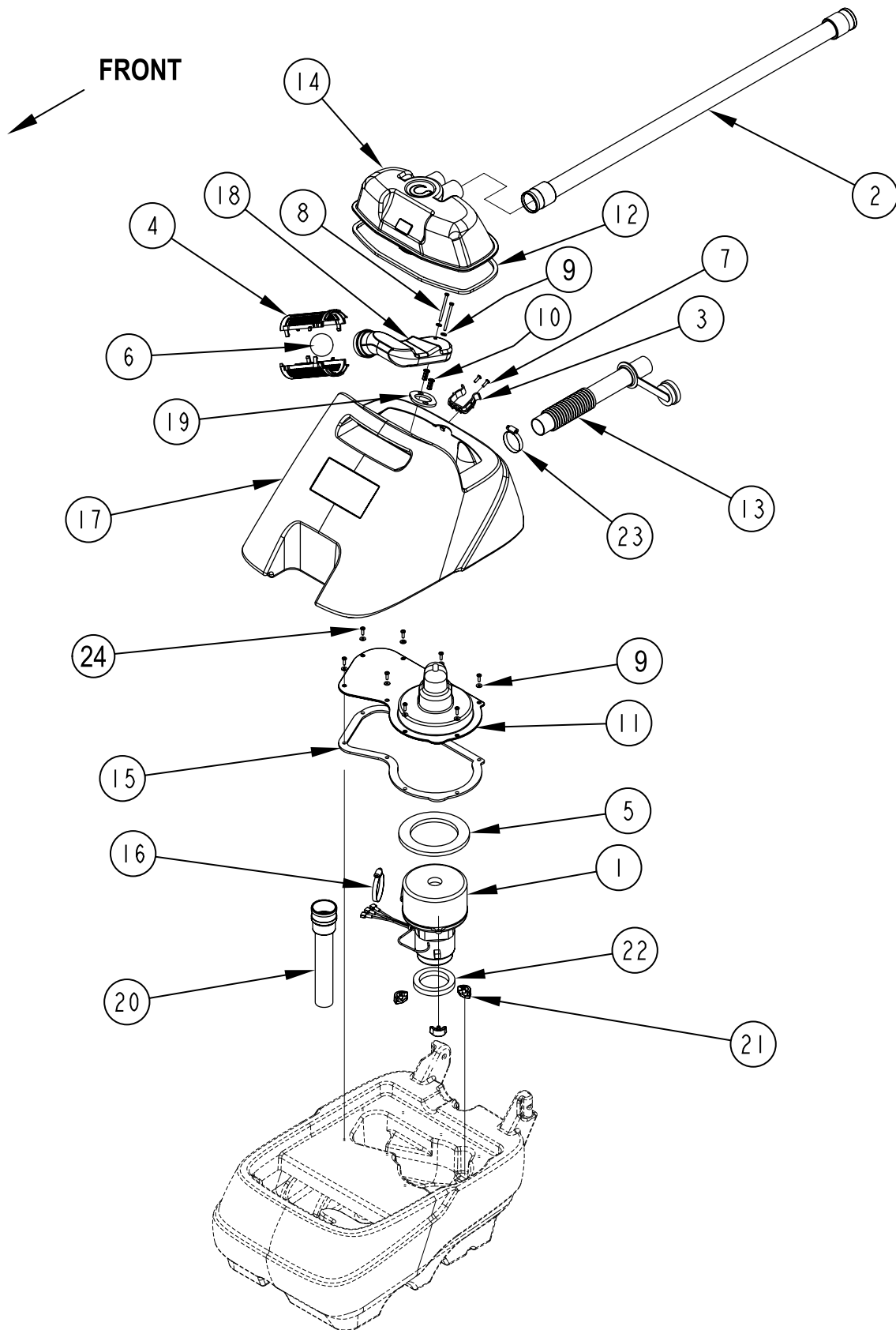

04-12

RECOVERY SYSTEM

06-10

Klenzor™ 16, 18 MPH**13**

Item	Ref. No.	Qty	Description
1	56265096	1	Vac Motor, 120V
*	56264453	1	Carbon Brushes for 56265096 (one pair)
2	56265142	1	Vac Hose 1.50 x 48.00 x 975018 (Klenzor 16)
	56265211	1	Vac Hose 1.50 x 54.00 x 975018 (Klenzor 18)
3	56331154	1	Clamp, Plastic
4	56324497	2	Cage, Float
5	56385437	1	Gasket
6	56391690	1	Ball, Float
7	56002124	2	Scr, Pan Phil 10-24 x .62
8	56003131	2	Scr, Hex SS 10-24 x 2.50
9	56009205	10	Wsh, Flt SS #10
10	56009374	2	Jack Nut
11	56265030	1	Cover, Vac Motor
12	56265032	1	Gasket
13	56265034	1	Hose, Drain 1.5 Inch
14	56265064	1	Recovery Lid
15	56265072	1	Gasket, Vac Cover
16	56440213	1	Clamp, Hose SAE #32
17	56265131	1	Tank, Recovery, 16 (16)
	56265133	1	Tank, Recovery, 18 (18)
18	56265134	1	Duct, Float
19	56265163	1	Gasket
20	56265202	1	Vac Hose Assy
21	56314484	3	Mount, Vibration
22	56314760	1	Gasket, Vacuum Duct
23	56329145	1	Clamp, Hose SAE #24
24	56002900	8	Scr, Pan Phil SS 10-24 x .50

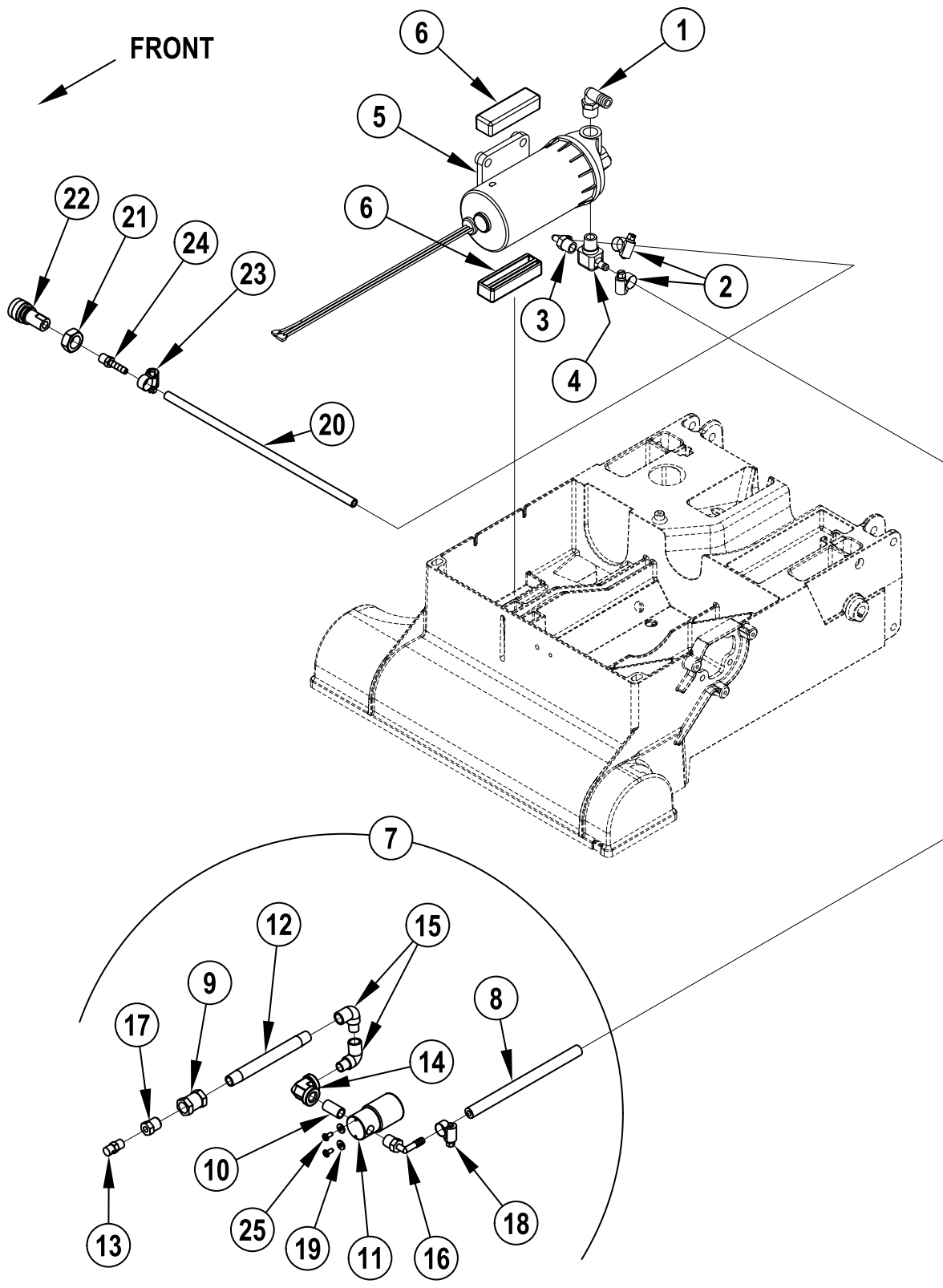

04-12

SOLUTION PUMP SYSTEM

06-10

Klenzor™ 16, 18 MPH**15**

Item	Ref. No.	Qty	Description
1	56900069	1	Barb, 90 Elbow 1/2 X 3/8NPT
2	56756364	2	Clamp, Hose SAE #4
3	56470138	1	Barb, 90 Elbow 1/4 x 1/4NPT
4	56264382	1	Adaptor, Barbed
5	56265051	1	Pump 115V
6	56265033	2	Mount, Pump
7	56265160	1	Nozzle/Valve Assy (16) (items 8-18)
8	56260841	1	7.00 Hose
9	56900032	1	Coupling
10	56150223	1	Nipple, 1/4NPT x .88/1.12
11	56265037	1	Valve, Solenoid 115V
12	56265040	1	Nipple, 1/4NPT x 5.00, Brass
13	56265052	1	Nozzle, Spray
14	56340782	1	Elbow, Pipe 1/4 NPT Brass
15	56369632	2	Elbow, 90 Street
16	56470138	1	Barb, 90 Elbow 1/4 x 1/4NPT
17	56740214	1	Bushing, Reducer
18	56756364	1	Clamp, Hose SAE #4
19	56002875	2	Wsh, Flt SAE SS #8
20	56220043	1	Solution Feed Hose
21	56009078	1	Nut, Hex Jam SS 5/8-18
22	56265208	1	Socket, 1/8 FPT
23	56756364	1	Clamp, Hose SAE #4
24	56369594	1	Barb, Adapter 1/4 x 1/8NPT
25	56003018	2	Scr, Pan Phil SS 8-32 x .38

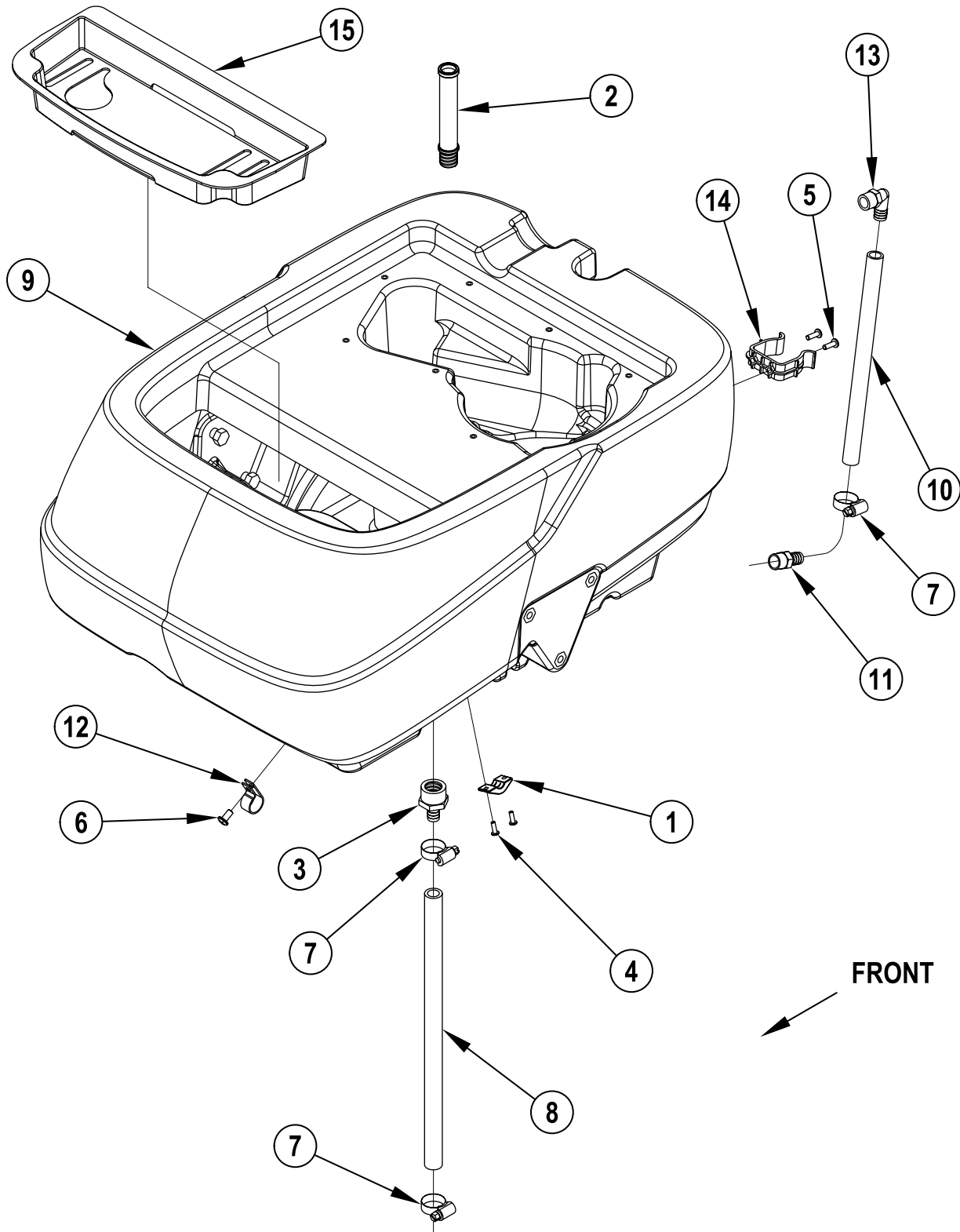

04-12

SOLUTION TANK ASSEMBLY

05-3

Klenzor™ 16, 18 MPH**17**

Item	Ref. No.	Qty	Description
1	56264119	1	Clamp, Power Cord (18 only)
2	56264137	1	Screen
3	56262190	1	Barb
4	56002003	2	Scr, Pan Phil 8-32 x .50 (18 only)
5	56002124	2	Scr, Pan Phil 10-24 x .62
6	56002145	1	Scr, Pan Phil 1/4-20 x .50 (18 only)
7	56219932	3	Clamp, Hose SAE #6
8	56387302	1	Hose, Spiral .500
9	56265132	1	Tank, Solution, 18 (18)
	56265130	1	Tank, Solution, 16 (16)
10	56265216	1	Hose, PVC Clear 11.00
11	56409507	1	Barb, Adapter 1/2 x 3/8NPT
12	56486112	1	Clamp, P (18 only)
13	56900069	1	Barb, 90 Elbow 1/2 x 3/8NPT
14	56331154	1	Clamp, Plastic
15	56265206	1	Lid, Solution Tank (16 only)

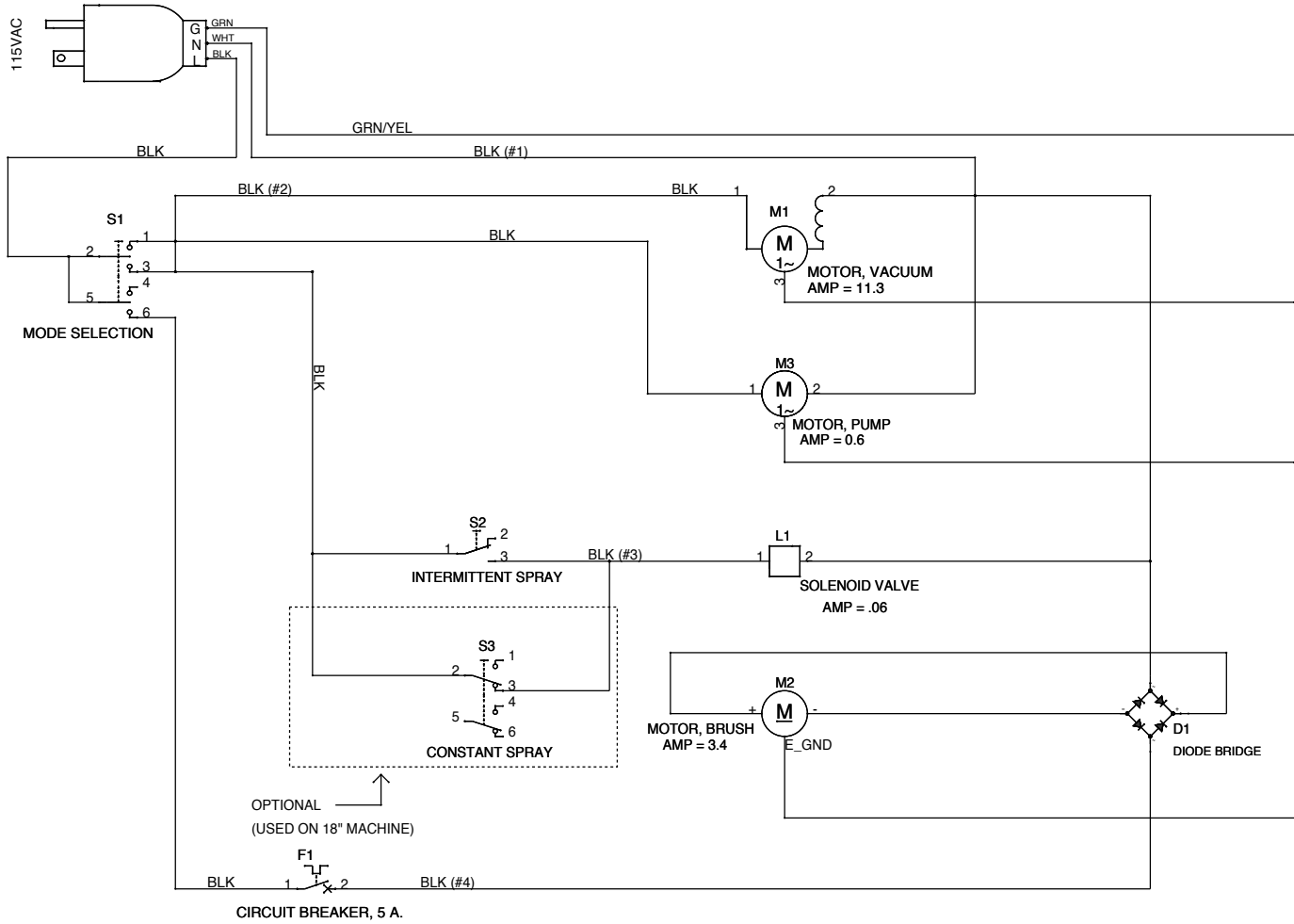

04-12

WIRING DIAGRAM

06-10

Klenzor™ 16, 18 MPH**19**

Item	Ref. No.	Qty	Description
D1	56265103	1	Rectifier, 35 Amp
F1	56265056	1	Circuit Breaker, 5 Amp
L1	56265037	1	Valve, Solenoid 115V
M1	56265096	1	Motor Vacuum, 120V
*	56264453	1	Carbon Brushes for 56265096 (one pair)
M2	56265075	1	Motor, Brush 115 VDC, 1/3 HP
M3	56265051	1	Motor, Pump 115V
S1	56265097	1	Switch, Mode Selection
S2	56265053	1	Switch, Intermittent Spray
S3	56265107	1	Switch, Constant Spray (18 only)
*	56265187	1	Wire Assembly (16, 18)
*	56265102	1	Wire Assembly (16, 18)
*	56265087	1	Wire Assembly (16, 18)
*	56265108	2	Wire Assembly (18)

* = Not Shown

Item	Ref. No.	Qty	Description
	56265150	1	Hard Floor Tool (items 1-16) (Optional)
1	56324350	2	Wheel
2	56400613	1	Gasket
3	56400614	2	Gasket
4	56105506	2	Blade Spec, Squeegee
5	56363855	2	Wheel
6	56471220	2	Bushing
7	56002850	2	Nut, Hex Nyl Loc-Thin SS 1/4-20
8	56002901	2	Scr, Hex Hd SS 1/4-20 x 1.50
9	56003037	2	Scr, Pan Phil SS 1/4-20 x .25
10	56003067	2	Scr, Pan Phil SS 1/4-20 x 1.00
11	56003269	2	Ring, Ret Ext Type E Reinf. 0.38 Dia.
12	56009047	4	Wsh, Flt .391 x .625 x .060
13	56009048	2	Nut, Wing Loc 1/4-20
14	56264336	1	Retainer
15	56264337	1	Channel
16	56265079	1	Squeegee Weldment

ACCESSORIES

04-12

22

Klenzor™ 16, 18 MPH

06-10

OPTIONAL BRUSHES

Brush Assembly Description	16"	18"
Nylon Brush Assembly	56265044	56265099
Blue Brush Assembly	56265175	56265177
240 Grit Brush Assembly	56265176	56265178

ACCESSORY TOOLS

Ref. No.	Description
56314402	Wand Assembly w/Soft and Hard Floor Tools
56265173	Wand Assembly w/Soft Floor Tool
56262209	Stand Up Wand
56220109	Hand Tool
56220070	Upholstery Hand Tool
56265174	15' Hose w/Waterline
56265112	Locking Extension Cord
56265368	8' Hose w/Waterline
56265150	Hard Floor Tool
56265309	Plug Adaptor Kit
56265305	Drag Wand
56265306	Scrub N Vac Wand
56250314	14" Scrub/Vac Tool

KENT
Simple. Clean.
14600 21st Avenue North
Plymouth, MN, 55447-3408
www.kenturoclean.com
Phone: 800-334-1083
Fax: 866-261-4779
©2006 Kent